

Industrial on-line Conductivity/Resistance controller

Operating manual

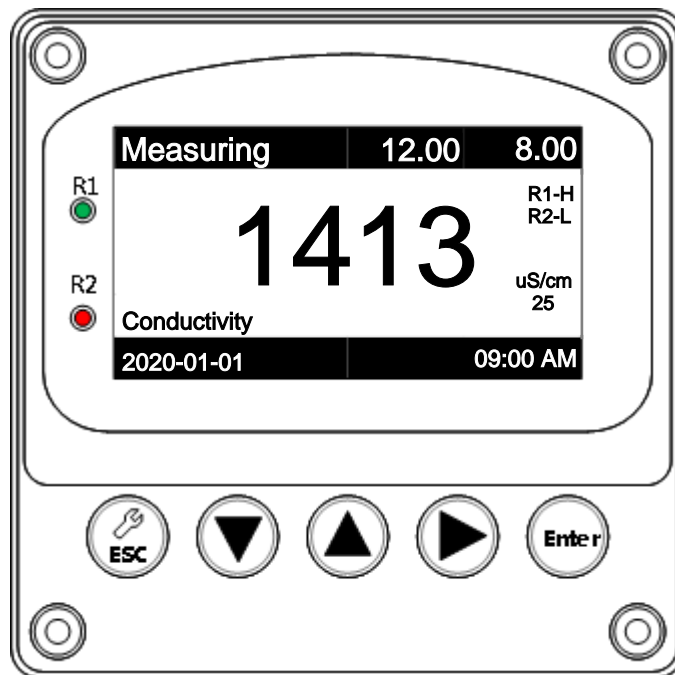

Initial password: 0000

Note: please read the manual carefully before use.

Thank you for purchasing our products. In order to continuously improve the quality of the controller and improve its functions, our company reserves the right to modify the content and icon display at any time. The actual display may be different from the operation manual, so the actual situation shall be subject to the machine. When using the controller, please follow the function and installation method described in the operation manual. Our company will not be responsible for any indirect or indirect loss or damage caused by improper use of the product by any person or entity. If you have any problems or find any omissions or errors in the operation manual, please contact our sales.

Safety and matters needing attention

1. Please read this manual carefully before installation to avoid safety problems and instrument damage caused by wrong records.
2. Please avoid high temperature, high humidity and corrosive environment to install the controller, and avoid direct sunlight exposure.
3. Special wires shall be used for the transmission line of electrode signal. It is suggested to use the wires provided by our company instead of general wires.
4. When using the power supply, it should avoid interference from the power supply, especially when using the three-phase power supply, the ground wire should be used correctly (if there is a power surge phenomenon occurs, the controller's power supply and control devices such as: dosing machine, mixer, etc. can be separated, that is, the transmitter uses a separate power supply.)
5. The controller output contacts carry alarm and control functions. For safety and protection reasons, please be sure to connect external relays with sufficient current value to protect the safety of the instrument.

Catalog

I Overview.....	4
II Combination and installation.....	5
2.1 Main engine fixed (panel mounting)	5
2.2 Panel mounting reference drawing.....	5
2.3 Electrode mounting.....	6
III Electrode and electrical wiring.....	10
3.1 Back wiring diagram.....	10
3.2 Back contact function diagram.....	11
3.3 Backplane terminal contact description.....	12
IV Panel introduction.....	13
4.1 Panel introduction.....	13
4.2 Key description.....	13
4.3 Display description.....	14
V Menu introduction.....	15
5.1 System setting.....	16
5.2 Sensor setting.....	17
5.3 Output setting.....	19
5.4 Factory reset.....	21
VI Calibration.....	22
VII Default factory setting.....	22
Maintanance.....	23

I Overview

This type of conductivity/resistance controller is a new controller. This meter has a high degree of intelligence and flexibility. It can measure conductivity/resistance value and temperature at the same time. It is widely used in urban sewage treatment plants, water supply and other industries and can continuously measured the conductivity/resistance value of solution.

Basic function

1. Language diversity. Factory standard is Chinese interface and can switch English interface.
2. Temperature compensation diversity. PT1000, NTC10K and manual temperature compensation are available in three temperature compensation modes.
3. Two 4-20MA outputs, corresponding to Conductivity/Resistance value and temperature, using isolation technology, strong anti-interference ability
4. The high and low points of the two sets of relays can be switched freely, and the hysteresis can be adjusted freely to avoid relays on and off frequently.
5. Password management function is to prevent the wrong operation by non-professional personnel.
6. Menu prompt function, greatly facilitates the user's operation.

Instrument technical parameters

Measuring range: 0.05uS/cm – 200mS/cm 0.00 MΩ·cm ~ 20.00 MΩ·cm

Accuracy: ± 0.01 us/cm

Resolution: 0.01uS/cm

Temperature compensation: 0–100 °C Manual / Auto(PT1000/NTC10K)

Signal output: 4-20mA isolation protection output, independent corresponding PH/ORP or temperature, maximum load is 500Ω.

Alarm output: two groups can randomly correspond to high and low point alarm (3A/250 V AC), normally open contact relay.

Power supply: AC100-240V or DC24V.

Power consumption: ≤5W

Environmental condition: (1) temperature 0 ~ 60 °C (2) humidity ≤85%RH

Dimensions: 96×96×132mm (H×W×D)

Hole size: 92.5×92.5mm (H×W)

II Combination and installation

2.1 Main engine fixed

This controller can be plated, wall-mounted installation.

2.2 Panel mounting reference drawing

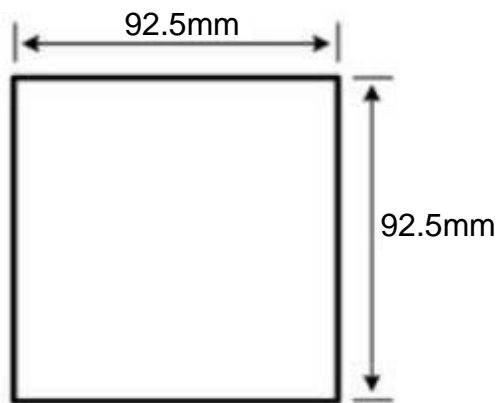

Cut off dimensions

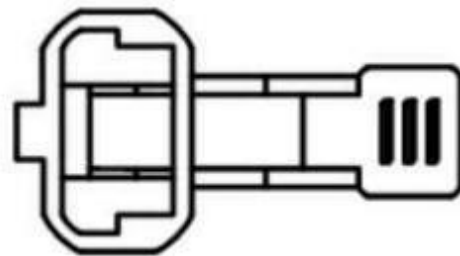

Mounting clips

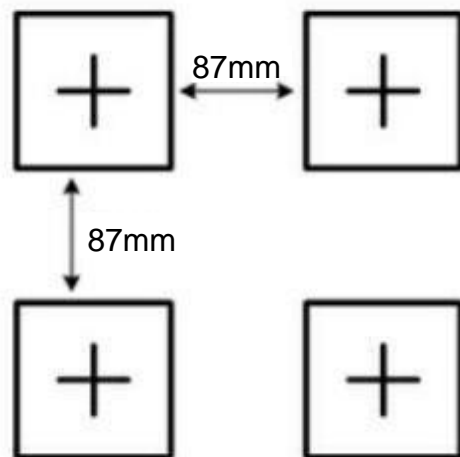
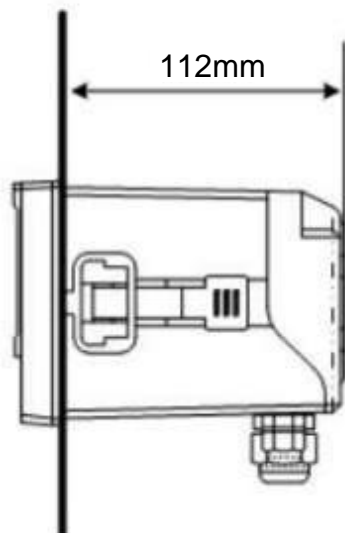

Control box cut-off dimensions

2.3 Electrode mounting

2.3.1 Electrode shape and installation form

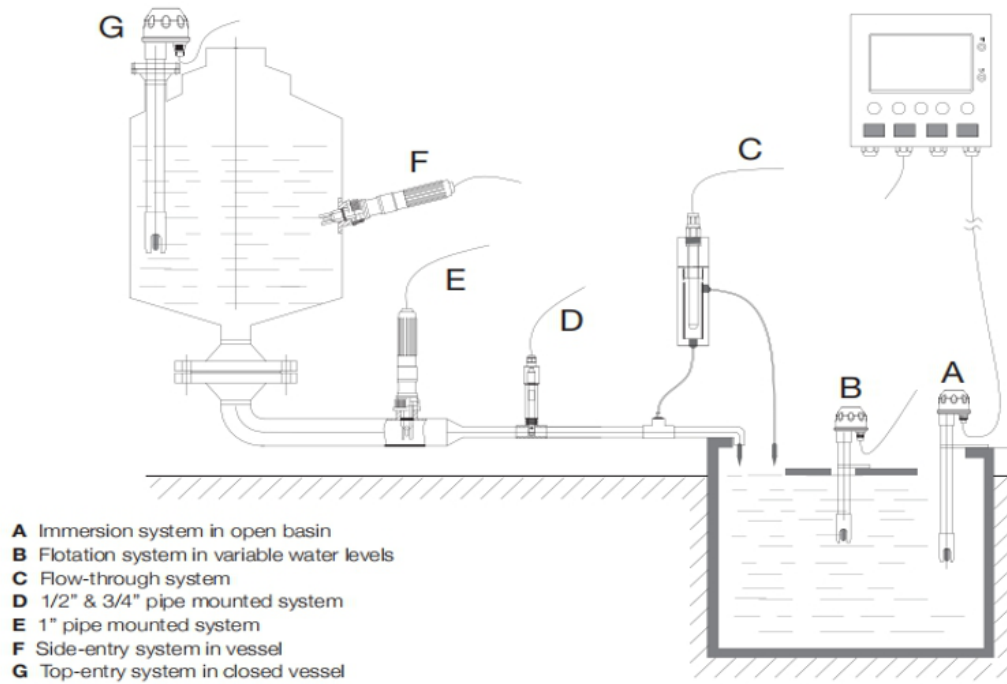
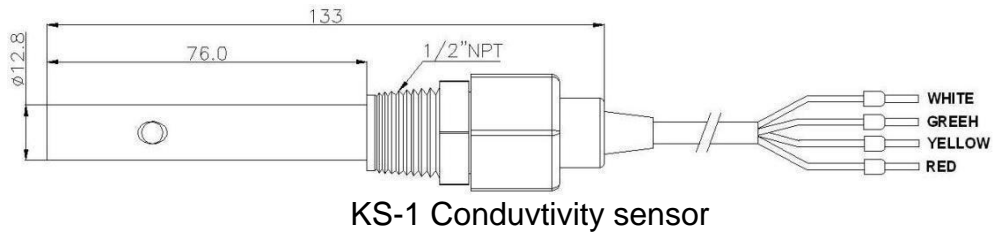

2.3.2 Common installation methods

Installation of sensors is a very careful work, please install sensors must carefully select the installation site, deliberate installation methods, so as to avoid the measurement data distortion.

1) The electrode joint in figure A is too long, and the extension part is too short. The dead cavity is easy to be formed in the sensor, resulting in measurement error. It should be installed according to figure B (go deep into the water direction=FLOW)

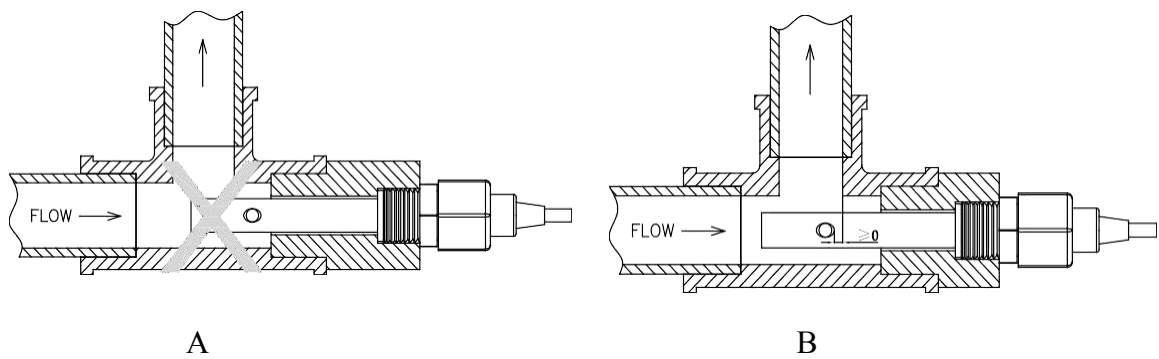

2) The installation mode of A will lead to the formation of the air cavity in the conductivity cell, resulting in measurement errors and instability, and should be installed as shown in figure B.

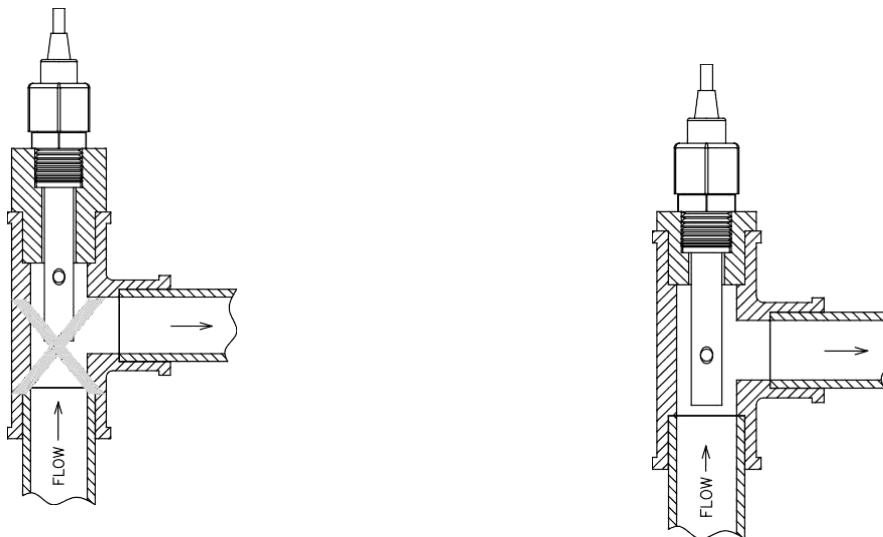

A WRONG

B The small round hole of the conductivity cell is located in the water outlet window.

3) Other common wrong installation methods:

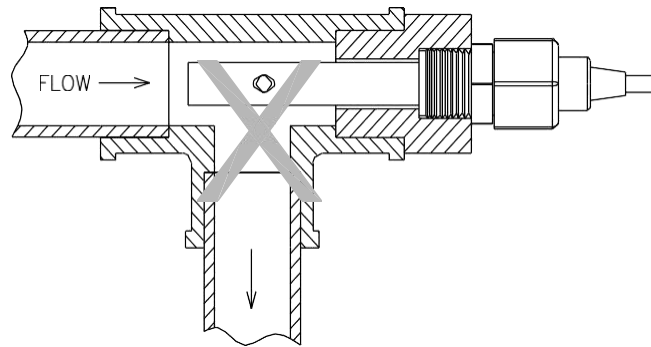

The measurement error or instability can be caused by the flow cannot guarantee the full pipe or high gas accumulation.

2.3.3 Installation precautions and maintenance

- 1) The flow cell should be installed in the pipeline where the flow rate is stable and it is not easy to produce bubbles. It can be installed in the way of side flow, so as to avoid inaccurate measurement.
- 2) The concentric tubular electrode paperback, oblique or vertical installation should be installed in the direction of FLOW and deep into the flowing water body; other structural shape electrodes prevent the dissipation pressure due to turbulence in the measurement room when electrode side direction installation and cause measurement data disorder.
- 3) The measurement signal is weak signal acquisition, the cable must be independent of the line. It is prohibited to connect with power line and control line in the same group of cable connectors or terminal boards and prohibited to wear pipe and tie with power line and control line, avoid interference with measurement or damage, breakdown instrument measurement unit.
- 4) The cable of the electrode is standard length and special cable before leave the factory. When the measuring cable needs to be lengthened, please make an agreement with the manufacturer before supply.

- 5) Please keep the electrode measurement part clean when installed. Don't touch the surface directly with hands or dirty objects. After contact with greasy dirt, grease and glue, the accurate value can't be measured for a longtime.
- 6) The conductivity cell is a precise measuring component. It can't be decomposed and change the shape and size of the electrode. It can't be cleaned, soaked and mechanically scraped by strong acid or alkali. These operations will lead to the change of electrode constant and affect the measurement accuracy of the system.
- 7) The measuring cable is the special cable, and the other specifications of cable can't be changed at will. All the incorrect change and change without permission will result in the error of measurement.
- 8) The instrument is made of precision integrated circuits and electronic components. It should not be installed in direct sunlight. It should be placed in a dry environment or in the control box to avoid leakage or measurement errors caused by water droplets sputtering or moisture.
- 9) In order to ensure the safe operation of the installation, connect the power after the installation has been checked correctly.

III Electrode and electrical wiring

3.1 Back panel wiring diagram

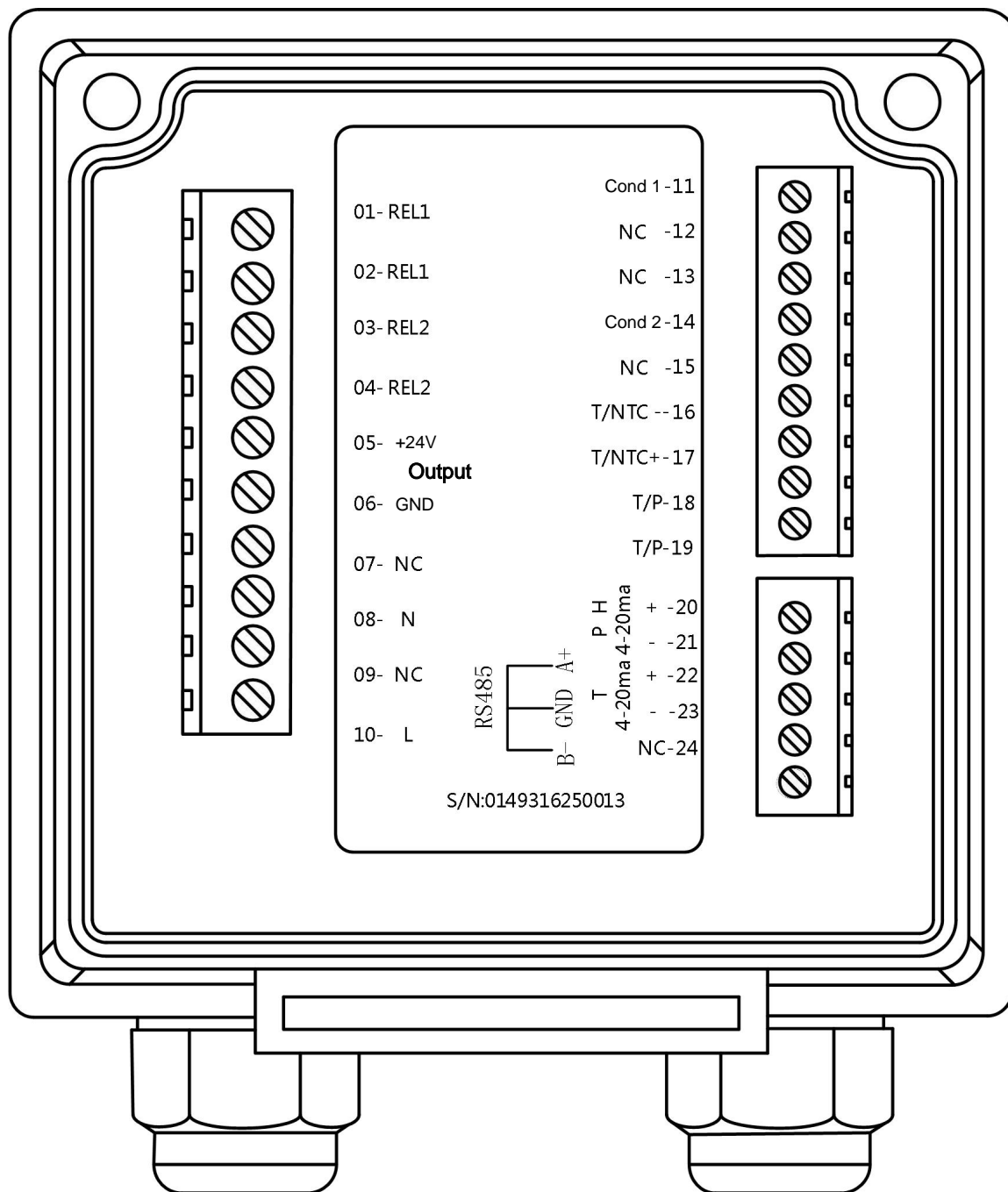

3.2 Back contact function diagram

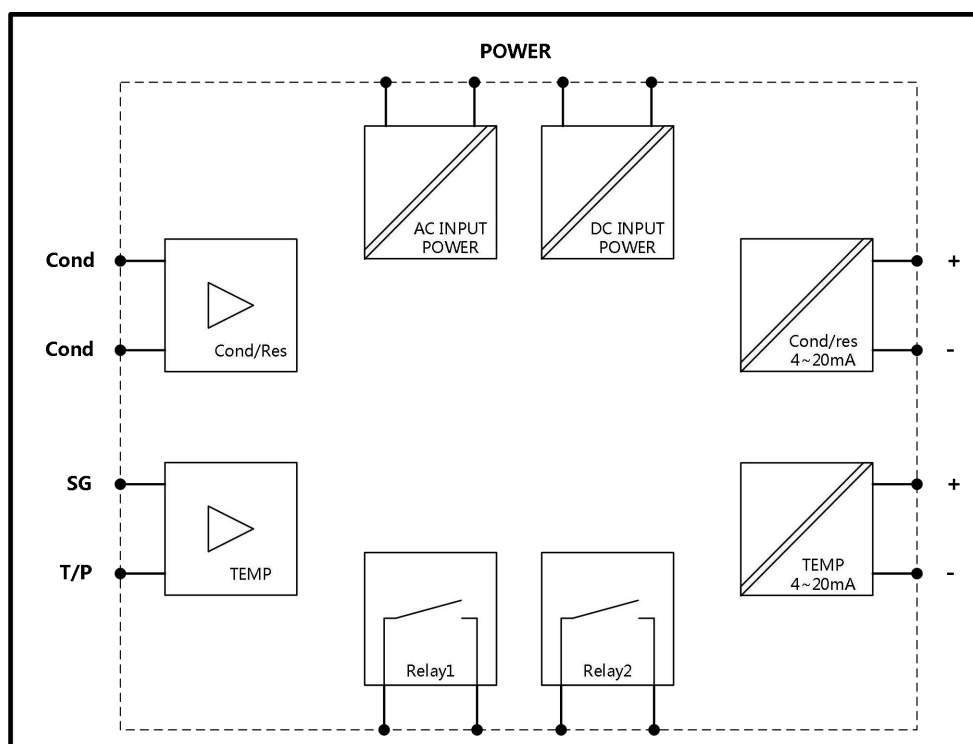

3.3 Backplane terminal contact description

- 01 REL1: First alarm control, external relay
- 02 REL1: First alarm control, external relay
- 03 REL2: Second alarm control, external relay
- 04 REL3: Second alarm control, external relay
- 05 DC:DC+24V output
- 06 DC:DC-24V output
- 07 NC:NC
- 08 AC:AC power supply 220V(L)
- 09 NC:NC
- 10 AC:AC power supply 220V(N)
- 11 Cond1: conductivity electrode blue wire
- 12 NC: NC
- 13 NC:NC
- 14 Cond2:conductivity electrode white wire
- 15 NC: NC
- 16 T/NTC:NTC10K temperature resistance interface1
- 17 T/NTC: NTC10K temperature resistance interface 2
- 18 T/P: PT1000 temperature resistance interface1
- 19 T/P: PT1000 temperature resistance interface2

- 20 Cond-ma(+):conductivity current output positive end
- 21 Cond-ma(-):conductivity current output negative end
- 22 T-ma(+):Temperature current output positive end/RS485 A connector
- 23 T-ma(-):Temperature current output negative end
- 24 NC:NC /RS485 B connector

Note: This instrument supports two groups of 4-20MA or one group of 4-20ma and one group of RS485.

AC input: 100~240VAC + 10% 50/60hz;

DC: 12-24V;

Power: 5W;

Relay: withstand voltage 240VAC, maximum current 0.5A

Output current: 500 Ω maximum resistance

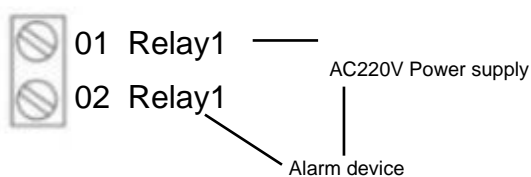
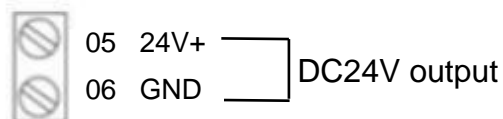
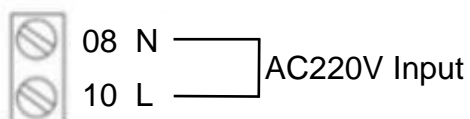

Alarm output



KS-1 Cond Sensor

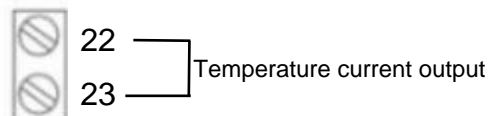

Current output

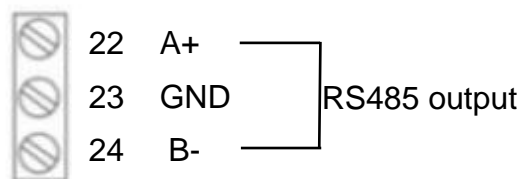

RS485 output



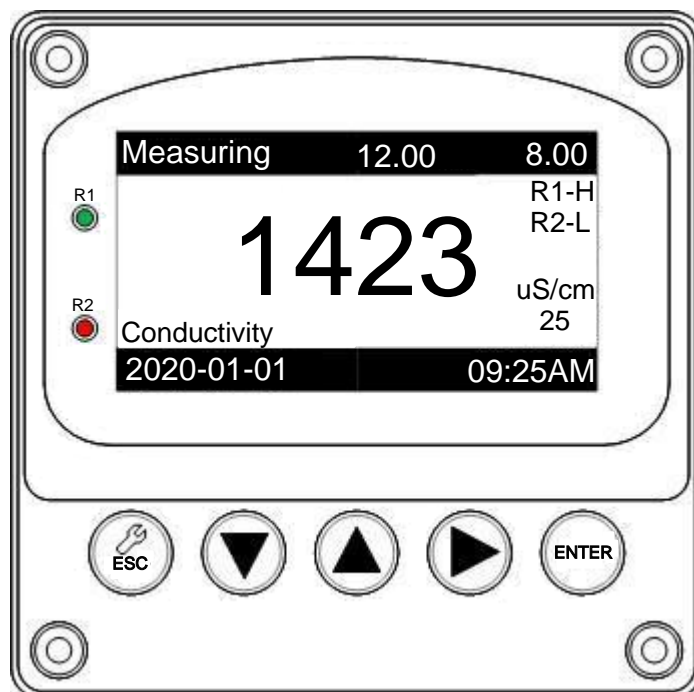

IV Panel introduction

4.1 Panel introduction



4.2 Key description

To prevent improper operation by non-users, enable password protection when entering parameter settings and corrections. Each function description is as follows:

-  **ESC** : Trigger the setting interface in the measurement mode, return to the previous menu under the setting interface.
-  : Switching and numerical adjustment of menus under the setting interface.
-  : Switching and numerical adjustment of menus under the setting interface.
-  : View historical alarm information in measurement mode, enter the next level menu under the setting interface, and the shortcut key of the alarm information interface.

Enter: View the basic parameters in measurement mode, and the setting interface is used to enter the next level menu, the shortcut key of the system information interface.

4.3 Display description

In the display mode of system measurement, it will be shown as follows:

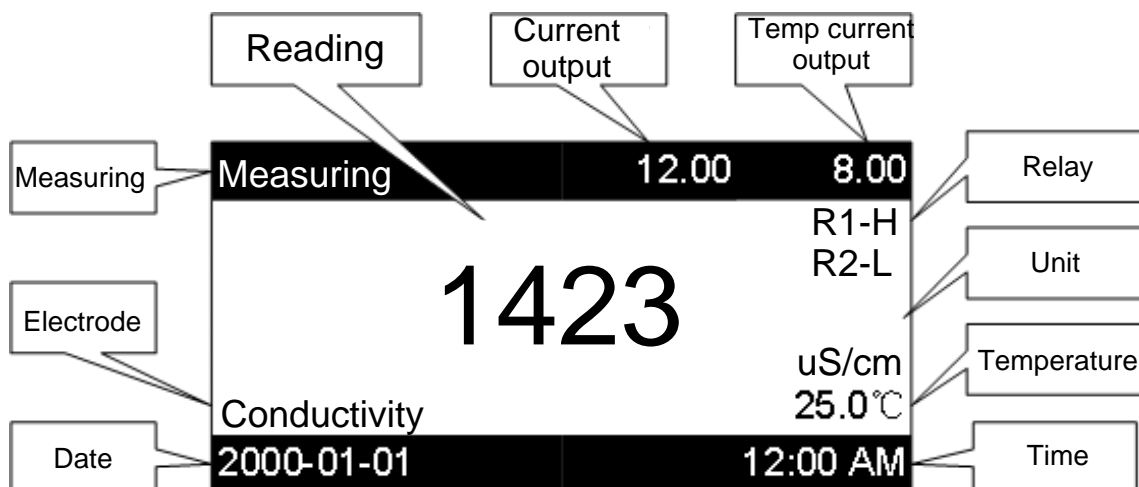

Indicator light description:

R1: Action indicator of relay 1, the high displays the red light, the low displays the green light.

R2: Action indicator of relay 2, the high displays the red light, the low displays the green light.

System Information	Alarm Information
Language: EN	1. 2018-10-31 31:63 R2-L
Sensor Type: RES/COND	2. 2018-10-31 28:00 R2-N
Unit: uS/cm	3. 2018-10-31 31:63 C1-H
Digital Filter: L	4. 2018-10-31 28:00 C1-L
ESC ▼ ▲ ▶ ENT	ESC ▼ ▲ ▶ ENT

The figure above shows the display interface of system information and alarm information respectively.

System information: All setting parameters of the meter are displayed in the system information. Press Enter to enter the system information interface.

Alarm information: Up to 60 relay alarm messages can be stored. Press the button ▶ to enter the alarm information interface.

V Menu introduction

This controller is divided into four first-level menus according to the function, and each level menu includes two or even two sub-menus. Each menu is numbered for easy viewing and setting of meter parameters. Moreover, the secondary menu will display the setting parameters of the lower menu instrument according to the function at the upper right of the screen, and the user can know the instrument parameters without entering the lower menu.

The main menu includes four first-level menus:

1. System setting

The system setting parameters of the instrument include language, password, date, backlight, etc.

2. Sensor setting

Includes display mode, calibration, digital filtering, temperature mode, temperature regulation, and compensation.

3. Output setting

Including relay 1, relay 2 and two 4-20ma parameter settings.

4. Factory reset

Including setting recovery and alarm information recovery.

Menu prompt function:

Enter the secondary menu and the parameter settings for the next menu will be displayed at the top right of the screen.

For example, enter the backlight of the system setup menu, the backlight parameter is set to 30 seconds.

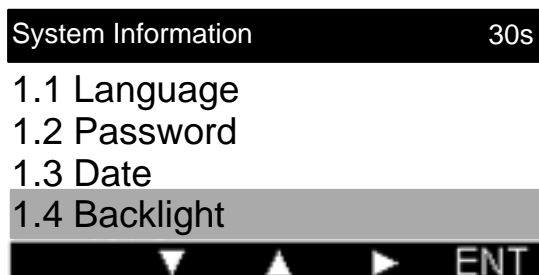

5.1 System setting

Menu 1.1 Language

This instrument supports Chinese and English two languages, two languages can switch freely.

For example: select simplified Chinese and press Enter key to confirm, the whole display interface of the instrument will be changed into simplified Chinese.

Note: In order to prevent the user from misoperation, after the customer selects the parameter and presses the Enter key, there will be four prompts “ESC”, “OK”, “NO” and “ENT” at the bottom of the screen, corresponding to the four buttons of the meter. The user needs to reconfirm whether the parameter is correctly selected. If yes, press the button ▼ that is “OK”, otherwise press ▲is“NO”.

Menu 1.2 Password

The default password of this instrument is 0000. You can change the password according to your own needs. After changing the password, the user will enter the new password after entering the setup menu next time.

Menu1.3 Date

This menu consists of two sub-menus.

1.3.1 Date format

1.3.2 Date setting

Menu 1.3.1 Date format

The meter supports the selection of three date formats, and you can select the appropriate date format according to your needs.

Menu 1.3.2 Date setting

Enter the date setting menu to set the year, month, day, hour, minute, and so on. After successful setting, the system time of the meter will automatically change to the set time.

```
Language zh
1.1.1 English
1.1.2 简体中文
```

```
ESC OK NO ENT
```

```
Password
```

```
0000
```

```
ESC ▼ ▲ ▶ ENT
```

```
Date Format Year-Month-Day
```

```
1.3.1.1 Year-Month-Day
```

```
1.3.1.2 Day-Month-Year
```

```
1.3.1.3 Month-Day-Year
```

```
ESC ▼ ▲ ▶ ENT
```

```
Date Settings 2000
```

```
1.3.2.1 Year
```

```
1.3.2.2 Month
```

```
1.3.2.3 Day
```

```
1.3.2.4 Hour
```

```
ESC ▼ ▲ ▶ ENT
```

Menu 1.4 Backlight

This instrument supports four kinds of backlight time, the user can set the corresponding backlight time according to the demand. The screen will darken when the meter reaches backlight time.

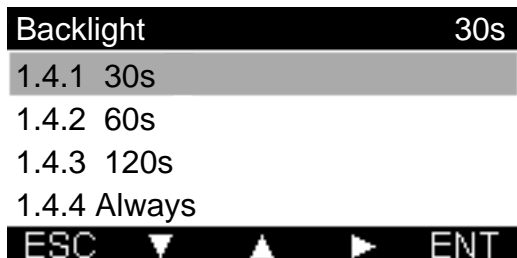

5.2 Sensor settings

Menu 2.1 Display mode

This instrument supports 6 display modes, each display mode represents different measurement accuracy and measurement unit selection.

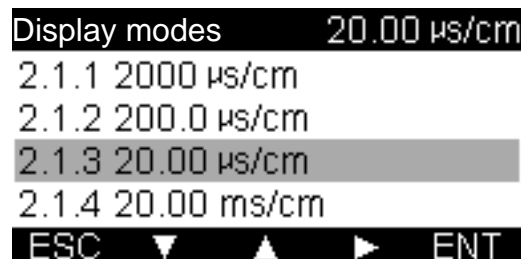

Remarks:

2000us/cm: The measuring range is **0-2000us/cm**, and the unit is **us/cm**.

200.0us/cm: The measuring range is **0-200us/cm**, the unit is **us/cm**.

0-20.00us/cm: The measuring range is **0-20.00us/cm**, the unit is **us/cm**.

0-20.00ms/cm: The measuring range is **0-20.00ms/cm**, the unit is **ms/cm**.

200.0ms/cm: The measuring range is **0-200.0ms/cm**, the unit is **ms/cm**.

20.00m Ω/cm: The measuring range is **0-20.00m Ω/cm**, the unit is **m Ω/cm**.

Menu 2.2 Coefficient settings

This controller chooses the suitable electrode coefficient according to the measuring range of water sample. The electrode coefficient is determined by the manufacturer and can be fine-tuned to achieve the purpose of correction.

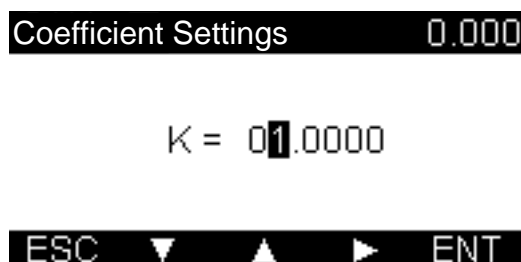

Note:

Coefficient=0.01 → **0.05-20uS/cm**

Coefficient=0.1 → **0.1-200uS/cm**

Coefficient=1.0 → **1.0-20.00mS/cm**

Coefficient=10.0 → **10-200mS/cm**

The user must determine the electrode coefficient before adjusting the coefficient, and then adjust the coefficient within the appropriate adjustment range to achieve the purpose of correction.

Menu 2.3 Digital filtering

The measured value of the meter is filtered by means of averaging, and three digital filtering methods are supported.

Low point: average every 5s.

Midpoint: average every 10s.

High point: average every 20s.

Note: The rate of change of the low point is higher than the rate of change of the high point.

```
Digital Filter L
```

```
2.3.1 L
```

```
2.3.2 M
```

```
2.3.3 H
```

```
ESC ▼ ▲ ▶ ENT
```

Menu 2.4 Temperature mode

The meter supports two types of temperature compensation, PT1000 and NTC10K. It can freely set two temperature display modes: Celsius and Fahrenheit.

Note 2.4.1 PTC°C: PT1000 temperature probe,

Celsius display mode.

2.4.2 NTC°C: NTC10K temperature probe,

Celsius display mode.

2.4.3 MTC°C: manual mode, Celsius display mode.

2.4.4 PTF°F: PT1000 temperature probe,

Fahrenheit display mode.

2.4.5 PTF°F: NTC10K temperature probe,

Fahrenheit display mode.

2.4.6 MTF°F: manual mode, Fahrenheit display mode.

```
Temperature mode PTC °C
```

```
2.4.1 PTC °C
```

```
2.4.2 NTC °C
```

```
2.4.3 MTC °C
```

```
2.4.4 PTF °F
```

```
ESC ▼ ▲ ▶ ENT
```

```
Temp Settings 0.0 °C
```

```
+001.0 °C
```

```
26.0 °C
```

```
ESC ▼ ▲ ▶ ENT
```

Menu 2.5 Temperature settings

The temperature adjustment is divided into two parts, the upper part is the temperature adjustment value, and the lower part is the adjusted temperature display value. Press Enter key, the temperature display of the meter will be the adjusted value.

Menu 2.6 Compensation

You can freely set the temperature compensation

```
Temp. Comp 0.00 %
```

```
+01.00 %
```

```
ESC ▼ ▲ ▶ ENT
```

parameter according to the actual situation. After pressing the Enter key to confirm, the measured value will change according to the temperature compensation parameter.

Note: The temperature compensation reference temperature of the instrument is fixed at 25 °C, and the calculation formula is:

$$C_t = C_{25} \{1 + \alpha(T - 25)\}$$

C25 is COND/Resistance value at 25 ° C. α is temperature compensation coefficient

T is temperature of the solution to be tested

Ct is temperature of T °C

5.3 Output setting

The output settings mainly include relay 1, relay 2 and two 4-20mA settings, of which two 4-20mA correspond to the measured values of temperature. The following takes the relay 1 and 4-20mA of dissolved oxygen as an example.

Menu 3.1 Relay 1

Relay 1 contains 3 sub-menus.

3.1.1 Relay 1 mode

3.1.2 Relay 1 trigger value

3.1.3 Relay 1 hysteresis value

Menu 3.1.1 Relay 1 mode

The relay is divided into three modes: off, high and low. Users can set the corresponding relay mode according to their needs, press Enter to confirm.

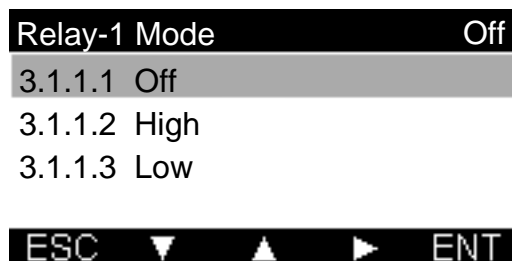

Menu 3.1.2 Relay 1 trigger value

The user can freely set the trigger value within the range allowed by the meter and press Enter to confirm.

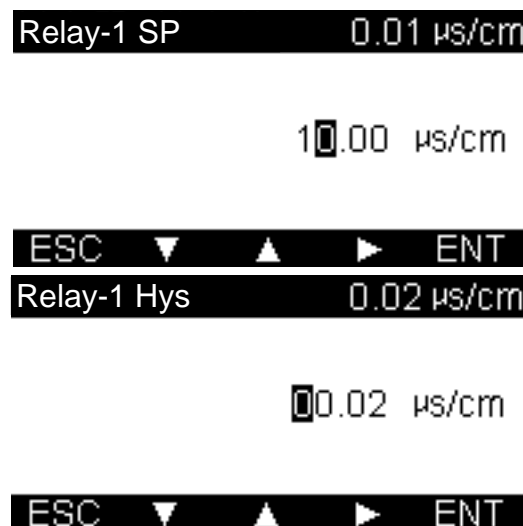

Menu 3.1.3 Relay 1 hysteresis value

The user can freely set the hysteresis value within the range allowed by the meter and press Enter to confirm.

Note:

Greater than (or less than) the alarm trigger value is pulled in. Below (or greater than) the hysteresis value is released. The relay action diagram is as follows:

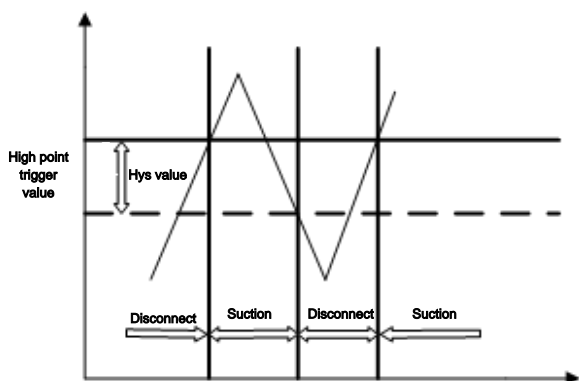

An example of the high point mode is:

Relay 1 mode = high point.

Relay 1 trigger value = 3000uS/cm.

Relay 1 lag value = 100uS/cm.

The working state of this setting relay is that when the display value is higher than 3000uS/cm, the relay is suction, and when it is lower than 2900uS/cm, the relay is disconnected.

In high point mode, Disconnect value = trigger value-Hys value

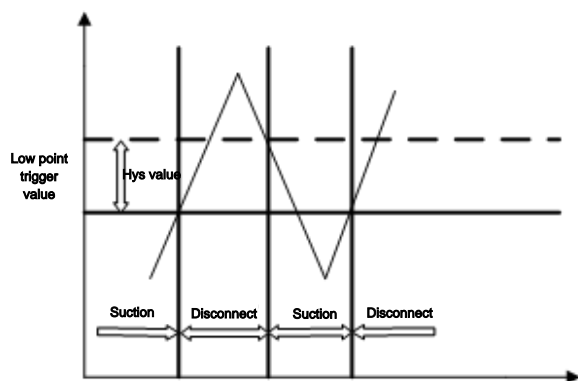

An examples of low-point mode:

Relay 1 mode = low point.

Relay 1 trigger value = 2000uS/cm.

Relay 1 lag value = 100uS/cm.

The working state of this setting relay is that the relay is suction when the display value is lower than 2000uS/cm and disconnected when it is higher than 2100uS/cm.

In low point mode, disconnect value = trigger value + Hys value

Menu 3.2 Relay 2

The setting of relay 2 is the same as the setting principle of relay 1, please refer to the setting of relay 1.

Menu 3.3 Electric current

This menu is divided into four sub-menus:

- 3.3.1 Electric current 1-4mA settings
- 3.3.2 Electric current 1-20mA settings
- 3.3.3 Electric current 1-4mA correction
- 3.3.4 Electric current 1-20mA correction

Since the setting and principle of correction of 4mA and 20mA of current are same, so 4mA setting and correction are taken as an example here.

Menu 3.3.1 Electric current 1-4mA settings

The user can freely set the current 1-4mA setting value. After pressing Enter, the system will automatically save the settings.

Current-1 Set. 4mA 0.05 uS/cm

0.05 uS/cm

ESC ▼ ▲ ► ENT

Menu 3.3.2 Electric current 1-20mA settings

The user can freely set the current 1-20ma setting value. After pressing Enter, the system will automatically save the settings.



Note: The conductivity value and current valueset in 4-20mA correspond to each other, andthe calculation formula is:

$$\text{outMa} = (20.00 - 4.00) / (\text{endMa} - \text{startMa}) * (\text{hold} - \text{startMa}) + 4.00$$

outMa is the value of output current

startMa is conductivity value set by 4mA

endMa is conductivity value set by 20mA

Hold is present measured value

For example, 4mA=0.00uS/cm, 20mA=20.00uS/cm, when the conductivity is 10.00uS/cm, the current output is 12.00mA.

Menu 3.3.3 Electric current 1-4mA correction

After entering the calibration interface, the current output value will be displayed on the screen. The ammeter will measure the output current value of the current 1 and adjust the current value on the screen to be the same as the current value measured by the ammeter.

**Menu 3.3.3 Electric current 1-20mA correction**

The setting principle of 20mA is the same as that of 4mA. Please refer to 4mA for correction.

Menu 3.4 Electric current2

The setting principle of current 2 is the same as that of current 1. Please refer to current 1.

5.4 Factory reset**Menu 4.1 Setting recovery**

Press Enter to confirm, all the parameter settings of the meter will be restored to the default value.

Menu 4.2 Alarm recovery

After pressing Enter key, the alarm information of the meter will be cleared.

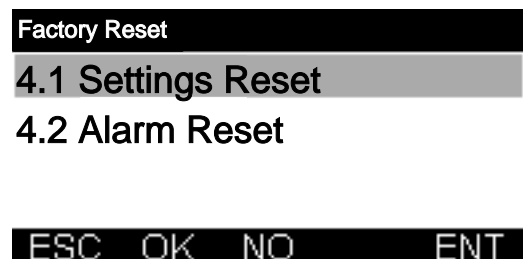

VI Calibration

The calibration of this control instrument is corrected by electrode coefficient, enters the 2.2 coefficient menu, selects the electrode coefficient of the electrode as (1.0 coefficient), dips the electrode into the correction liquid (such as 1413uS/cm).

Coefficient Settings 0.000

K = 01.0000

ESC ▼ ▲ ► ENT

Adjust the value of the electrode coefficient by

▼ / ▲ / ► button (such as adjusting the

Coefficient Settings 0.000

K = 00.9960

ESC ▼ ▲ ► ENT

coefficient to 0.996) press **Enter** to confirm, so that the measured value and the actual correction liquid value is consistent with the correction can be completed.

VII Default factory setting

Menu name	Range setting	Factory default
Measurement unit	us/cm / MΩ.cm	us/cm
Digital filtering	Low/middle/high point	Low point
Temperature compensation	PTC/NTC/Manual	Manual
Manual temperature compensation	0.0 ~ 100.0 °C	25.0 °C
High alert trigger value	0.00 ~ 20.00 us/cm	15.00 us/cm
High alert hysteresis value	0.00 ~ 20.00 us/cm	1.00 us/cm
Low alert trigger value	0.00 ~ 20.00 us/cm	5.00 us/cm
Low alert hysteresis value	0.00 ~ 20.00 us/cm	1.00 us/cm
4mA corresponding value	0.00 ~ 20.00 us/cm	0 us/cm
20mA corresponding value	0.00 ~ 20.00 p us/cm	20.00 us/cm
user password	0 ~ 9999	0000 (general password:6666)
Backlight	30s~Always	30s

Maintenance

	Possible factors	Check method
1. Without display	A. The power is not on. B. Meter fault.	A. Check for 220V voltage between (01) (03) B. Request professional maintenance.
2. Instability of display	A. The electrode wiring is wrong. B. Bubbles in the line C. Unstable water quality D. The power supply has strong interference.	A. Check the cables B. Pipeline rectification or alternative measurement points C. Eliminating Instrument Reasons with Stable Water Source D. TV Reasons and Measures for Power Supply
3. Reading errors	A. The constant is set incorrectly B. Changes in electrode constants C. Measuring the rate of flow is too fast or dead water	A. Resetting Constants B. Replacement of new electrodes C. Install the electrode at a slower flow rate
4. The controller has a value after the electrode leaves the water	A. Reduced electrode permeable or cable insulation B. There's a foreign body between the electrodes. C. Terminals are affected by moisture	A. Replacing new electrodes B.C. To find out the causes and deal with them
5. Alarm is ringing, relay does not work	A. Relay steam, Contact does not switch position B. Relay no sound	A. Replacement of relays (contact ablation) B. Circuit failure, repairing

