

Industrial on-line pH/ORP controller

Operating manual

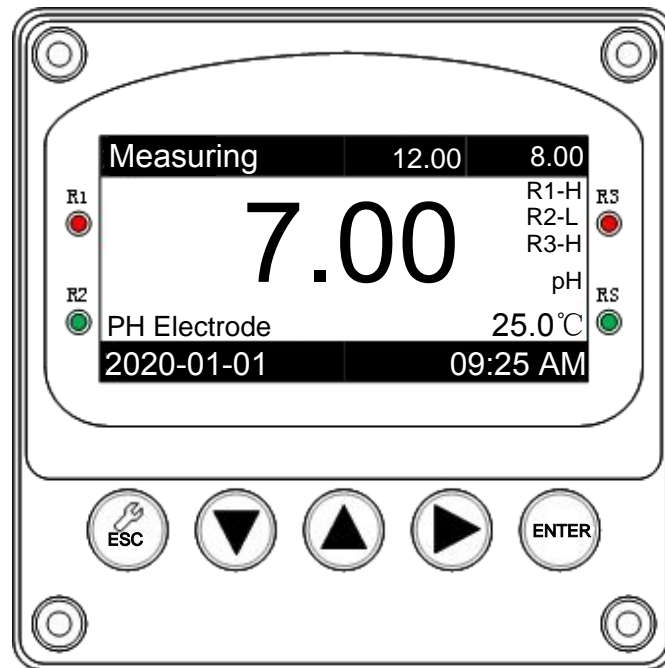

Initial password: 0000

Note: please read the manual carefully before use.

Thank you for purchasing our products. In order to continuously improve the quality of the controller and improve its functions, our company reserves the right to modify the content and icon display at any time. The actual display may be different from the operation manual, so the actual situation shall be subject to the machine. When using the controller, please follow the function and installation method described in the operation manual. Our company will not be responsible for any indirect or indirect loss or damage caused by improper use of the product by any person or entity. If you have any problems or find any omissions or errors in the operation manual, please contact us!

Safety and matters needing attention

1. Please read this manual carefully before installation to avoid safety problems and instrument damage caused by wrong records.
2. Please avoid high temperature, high humidity and corrosive environment to install the controller, and avoid direct sunlight exposure.
3. Special wires shall be used for the transmission line of electrode signal. It is suggested to use the wires provided by our company instead of general wires.
4. When using the power supply, it should avoid interference from the power supply, especially when using the three-phase power supply, the ground wire should be used correctly (if there is a power surge phenomenon occurs, the controller's power supply and control devices such as: dosing machine, mixer, etc. can be separated, that is, the transmitter uses a separate power supply.)
5. The controller output contacts carry alarm and control functions. For safety and protection reasons, please be sure to connect external relays with sufficient current value to protect the safety of the instrument.

Catalog

I Overview.....	4
II Combination and installation.....	5
2.1 Main engine fixed (panel mounting)	5
2.2 Panel mounting reference drawing.....	5
2.3 Sensor and protection tube.....	6
III Electrical wiring.....	10
3.1 Back wiring diagram.....	10
3.2 Back contact function diagram.....	11
3.3 Backplane terminal contact description.....	12
IV Panel introduction.....	13
4.1 Panel introduction.....	13
4.2 Key description.....	13
4.3 Display description.....	14
V Menu introduction.....	15
5.1 System settings.....	15
5.2 Sensor settings.....	17
5.3 Output settings.....	19
5.4 Factory reset.....	24
VI Default factory settings.....	25
Maintenance.....	26

I Overview

This controller has a high degree of intelligence and flexibility. It can measure pH/ ORP value and temperature at the same time.

It is widely used in urban sewage treatment plants, water supply and other industries and can continuously measure the pH/ORP value of solution.

Basic function

1. Language diversity. Factory standard is Chinese interface and can switch to English interface.
2. Temperature compensation diversity. PT1000, NTC10K and manual temperature compensation are available in three temperature compensation modes.
3. 4-20mA outputs, corresponding to PH/ORP value and temperature, using isolation technology, strong anti-interference ability
4. The high and low points of the three sets of relays can be switched freely, and the hysteresis can be adjusted freely to avoid relays on and off frequently.
5. Password management function is to prevent the wrong operation by non- professional personnel.
6. Menu prompt function, greatly facilitates the user's operation.

Instrument technical parameters

Measuring range: PH(0~14PH, 0.0~14.0PH, 0.00~14.00PH) ORP(-1999 ~ 1999 MV) Accuracy: ± 0.01 pH; ± 1 mV

Resolution: 0.01pH; 1mV

Temperature compensation: 0~100 °C Manual / Auto(PT1000/NTC10K)

Signal output: 4-20mA isolation protection output, independent corresponding PH/ORP or temperature, maximum load is 500Ω.

Alarm output: Three-group can randomly correspond to high and low point alarms (3A/250 V AC), normally open contact relay.

Power supply: AC100~240V or DC

24V. Power consumption: ≤ 5 W

Environmental condition: (1) temperature 0~60 °C (2)

humidity $\leq 85\%$ RH Dimensions: 96×96×132mm (H×W×D)

Cut off dimensions: 92.5×92.5mm (H×W)

II Combination and installation

2.1 Main engine fixed (panel mounting)

Note: For panel installation, please reserve a square hole of 92.5*92.5mm on the panel of control box.

2.2 Panel mounting reference drawing

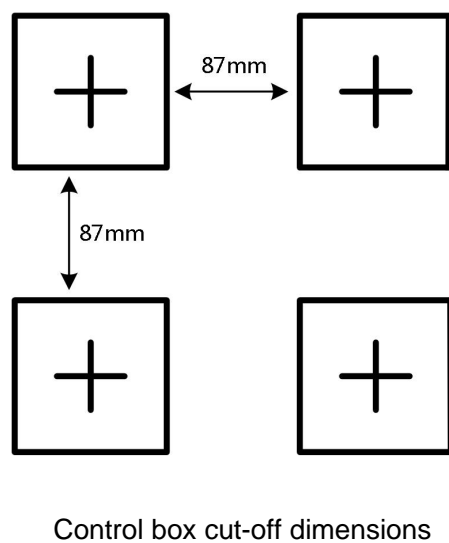
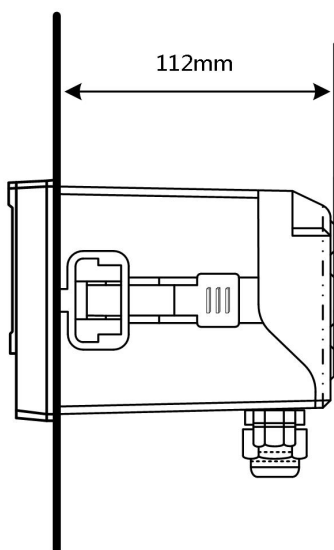
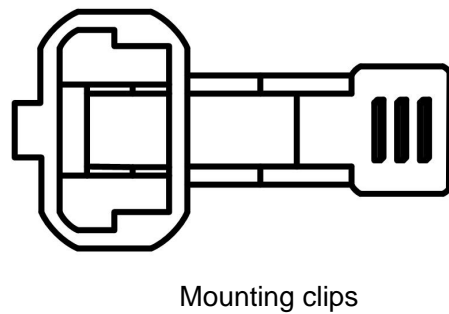
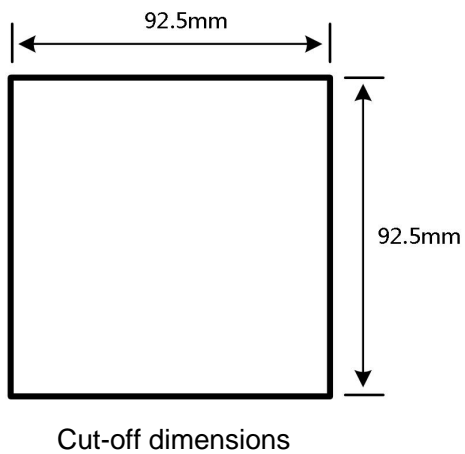

2.3 Sensor and protection tube

2.3.1 Sensor cable

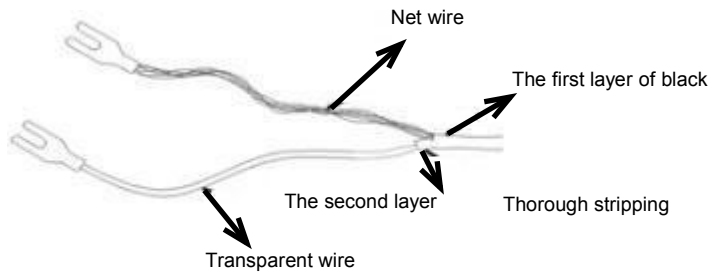

Configuration of coaxial cable:

Center line: + sensor wire line: - sensor reference line

The correct configuration diagram like up, the outer peel of the black rubber mandrel guide be stripped off. Conductive rubber or aluminum foil sensor signal line of the central axis and the cable must be stripped off. The cable extends to the middle of the host, can't have any contact, directly to the central axis of the cable to the GLASS contact is connected to the back of the host, the cable connected to the Ref contact.

Note: if the standard cable can't meet the requirements, shall not extend t he cable, please contact the supplier to provide a dedicated cable, otherwise the instrument produces adverse consequences to bear. Recommended site not more than 30m to extend the cable, or need to increase the signal amplifier.

Installation

How to build a pH Measurement System

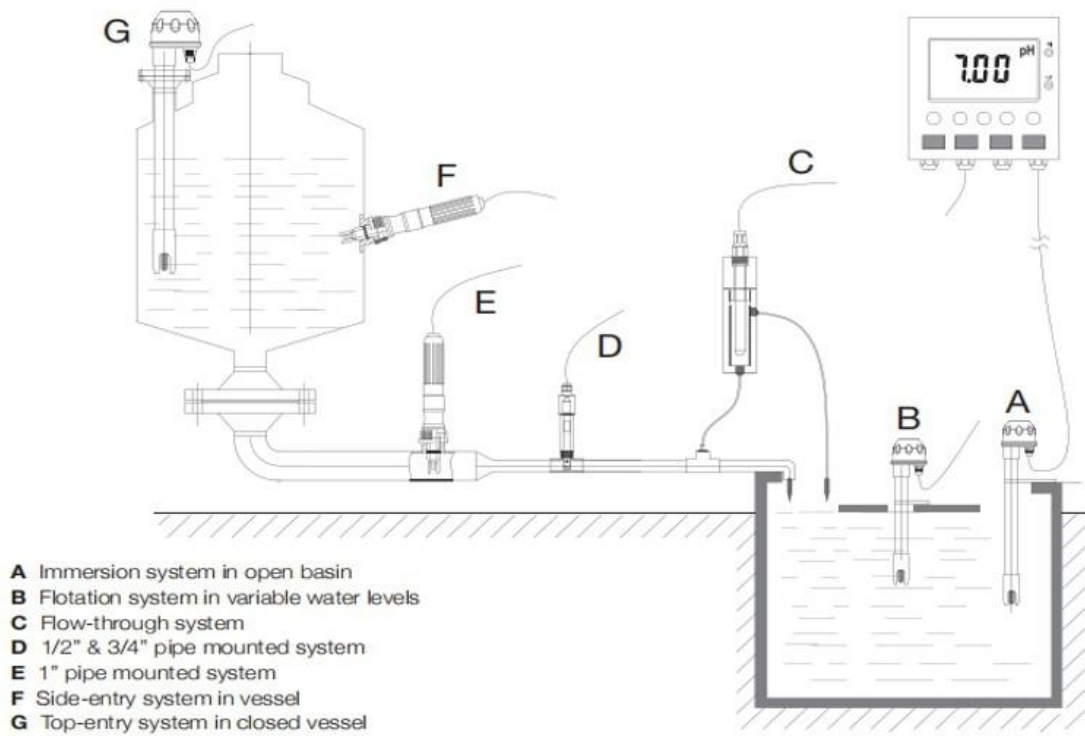

Pipeline Installation Considerations

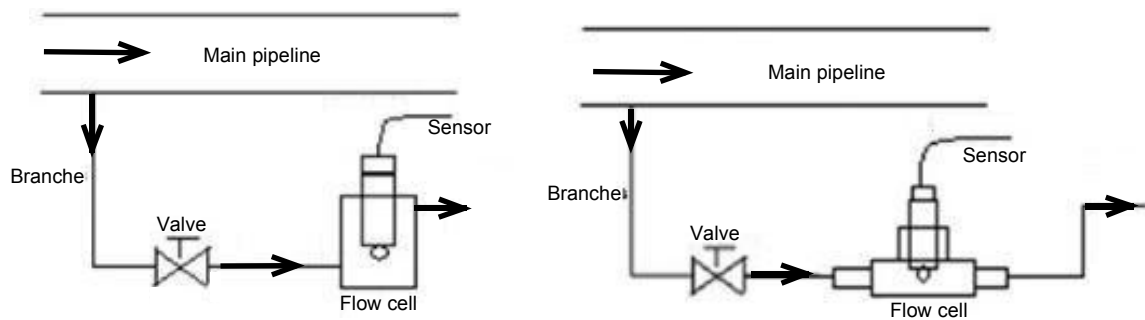

- Note: (1) The sensor should be installed in the bypass of the main pipeline, the front end should install the valve, control the flow rate, the flow rate should be as small as possible, generally as long as the outlet has a stable aqueous solution dripping out can be. The sensor should be installed vertically and penetrate into the active water body, and the outlet should be higher than the inlet to ensure that the electrode is completely immersed in the solution.
- (2) The sensor should be calibrated before installation.
- (3) The measuring signal is a weak electrical signal, its acquisition cable should be independent wiring, and the power line, control line connected to the same set of cable connectors or terminal panels, so as not to interfere with or penetrate the measuring unit.

Plastic shell sensor sink type installation

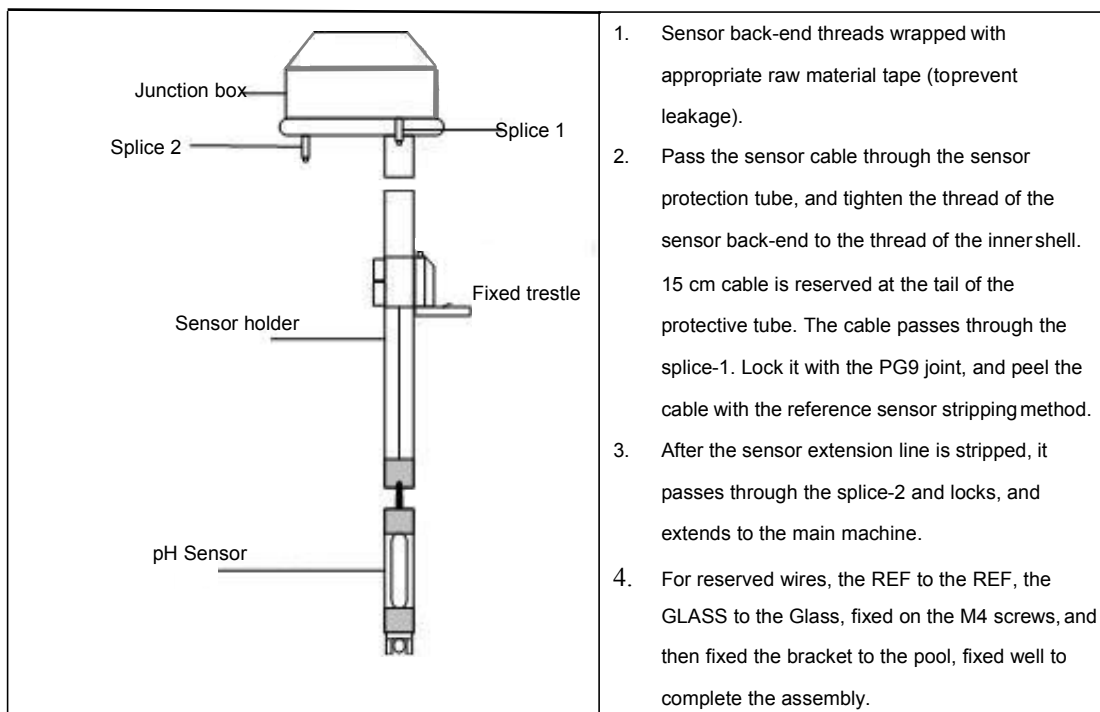

Glass shell sensor sink type installation

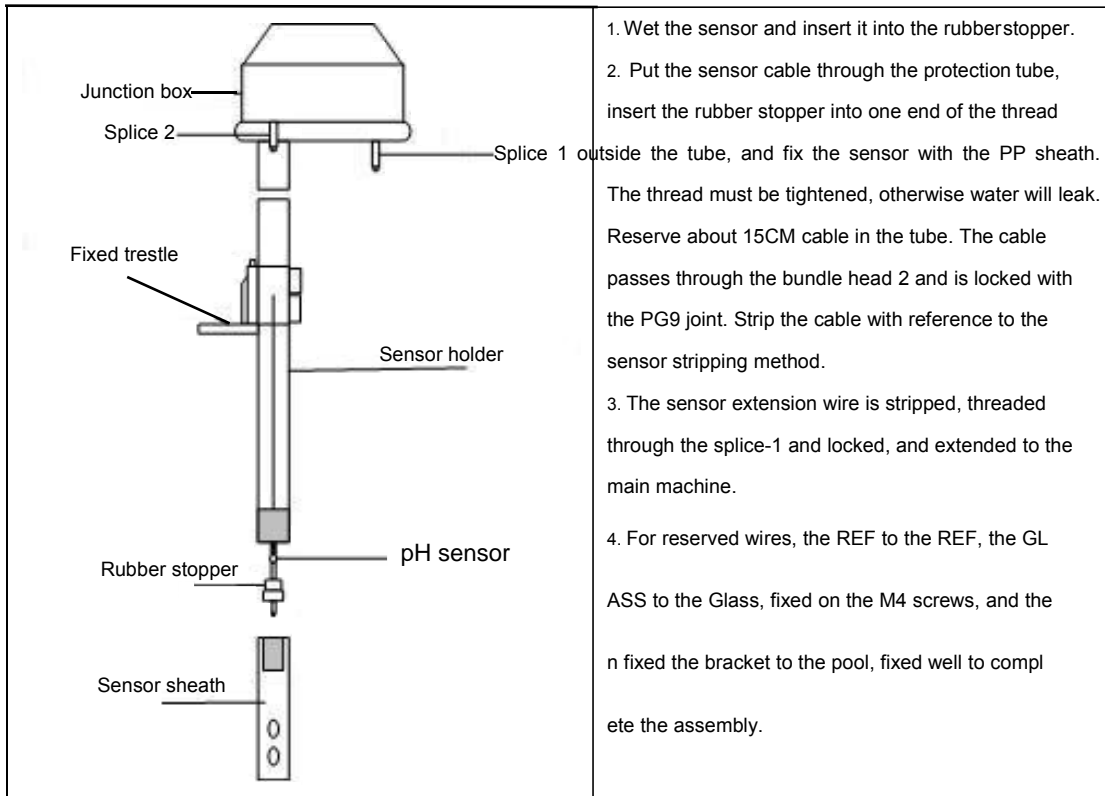

III Electrical wiring

3.1 Back wiring diagram

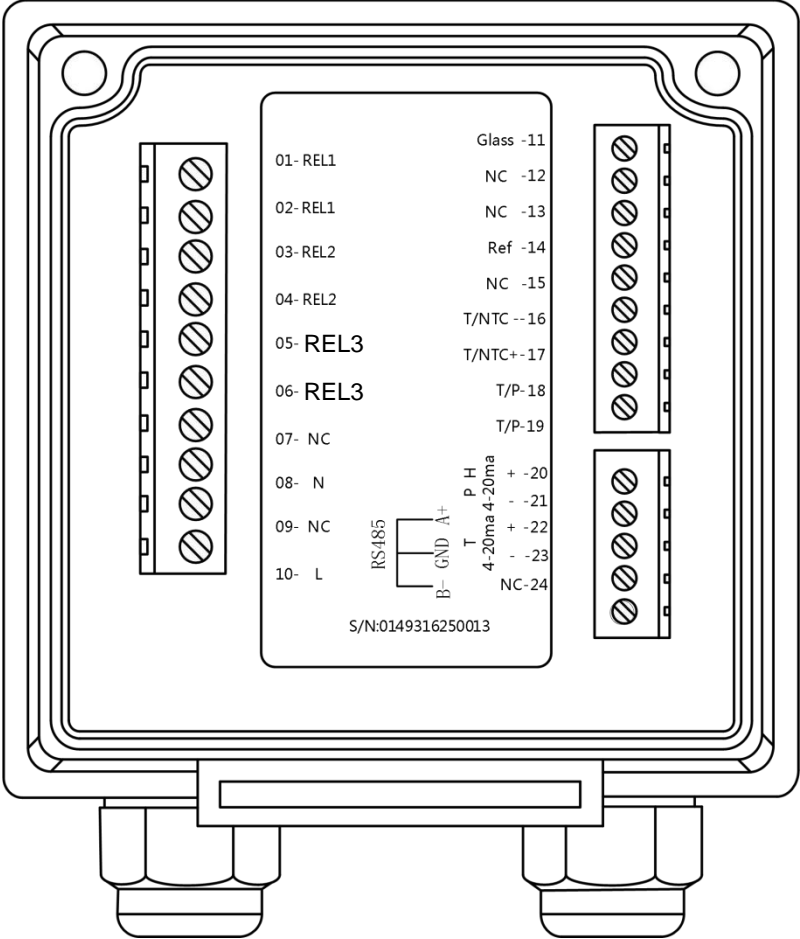

3.2 Back contact function diagram

- 01 REL1: First alarm control, connect to external relay
- 02 REL1: First alarm control, connect to external relay
- 03 REL2: Second alarm control, connect to external relay
- 04 REL2: Second alarm control, connect to external relay
- 05 REL3: Third alarm control, connect to external relay
- 06 REL3: Third alarm control, connect to external relay
- 07 NC: NC
- 08 AC: AC power supply 100-240V(L), DC: 24V+
- 09 NC: NC
- 10 AC: AC power supply 100-240V(N), DC: 24V-
- 11 Glass: pH/ORP +
- 12 NC: NC
- 13 NC: NC
- 14 Ref: pH/ORP -
- 15 NC: NC
- 16 T/NTC: NTC10K temperature resistance interface 1
- 17 T/NTC: NTC10K temperature resistance interface 2
- 18 T/P: PT1000 temperature resistance interface 1
- 19 T/P: PT1000 temperature resistance interface 2
- 20 pH-ma(+): pH/ORP current output positive end
- 21 pH-ma(-): pH/ORP current output negative end
- 22 T-ma(+): Temperature current output positive end/RS485 A connector
- 23 T-ma(-): Temperature current output negative end
- 24 NC: NC /RS485 B connector

AC: 100~240VAC + 10%

50/60hz; DC: 24V;

Power: 7W;

Relay: withstand voltage 220VAC, maximum current

0.5A Output current: 500 Ω maximum resistance.

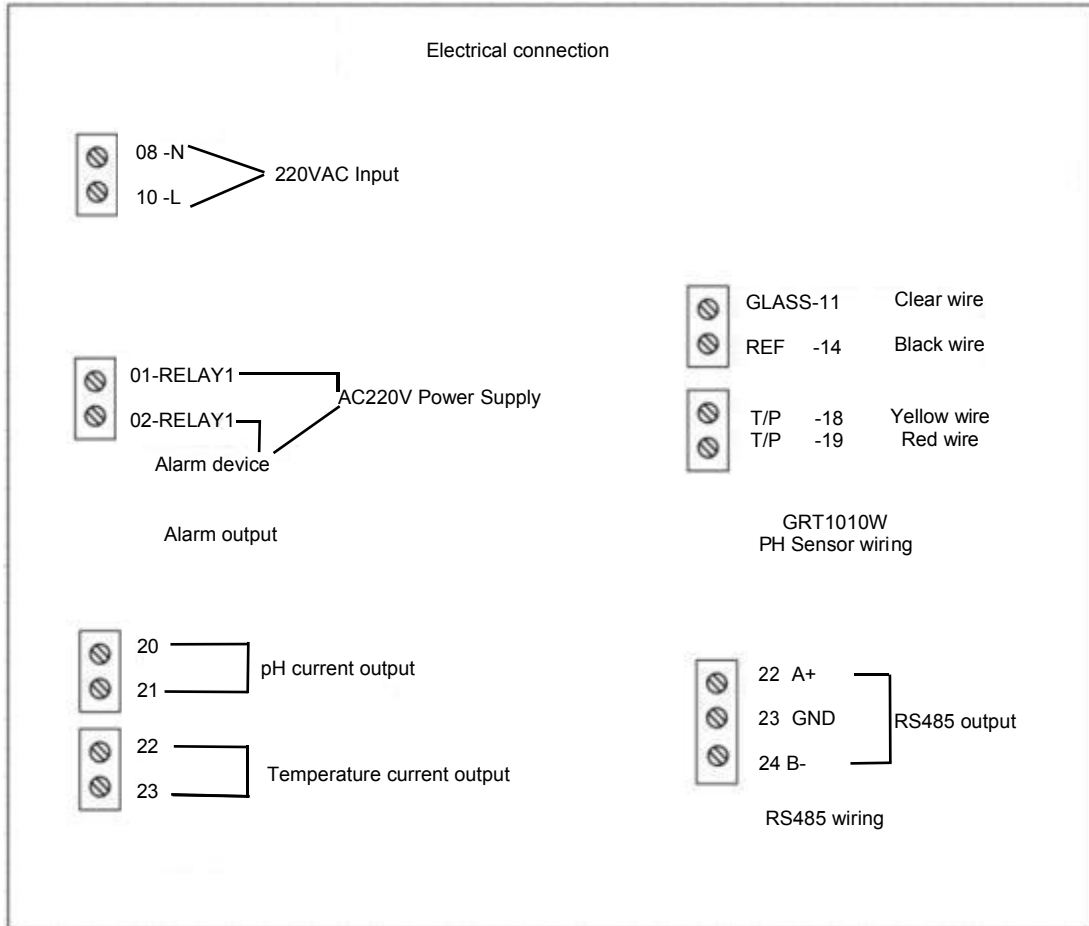

IV Panel introduction

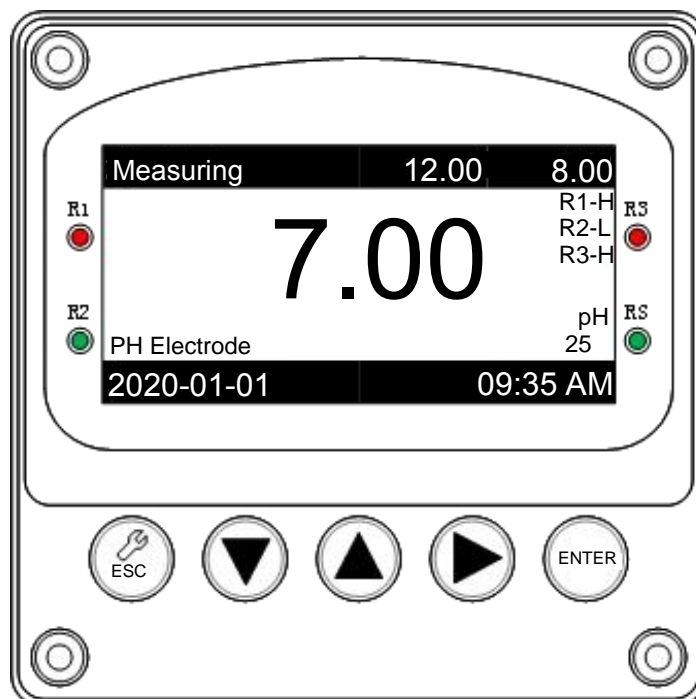

4.1 Panel introduction



4.2 Key description

To prevent improper operation by non-users, enable password protection when entering parameter settings and corrections. Each function description is as follows:

 **ESC** : Trigger the setting interface in the measurement mode, return to the previous menu under the setting interface.

 : Switching and numerical adjustment of menus under the setting interface.  : Switching and numerical adjustment of menus under the setting interface.  : View historical alarm information in measurement mode, enter the next

level menu under the setting interface, and the shortcut key of the alarm information interface.

Enter: View the basic parameters in measurement mode, and the setting interface is used to enter the next level menu, the shortcut key of the system information interface.

4.3 Display description

In the display mode of system measurement, it will be shown as follows:

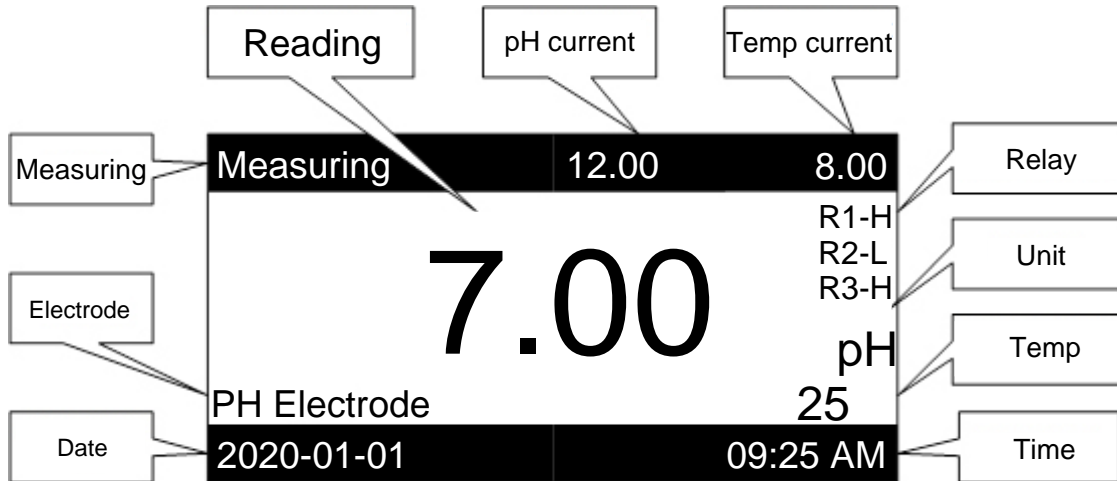

Indicator light description:

R1:Action indicator of relay 1,the high displays the red light, the low displays the green light.

R2:Action indicator of relay 2,the high displays the red light, the low displays the green light.

System Information
Language: EN
Sensor Type: PH
Unit: pH
Digital Filter: L
ESC ▼ ▲ ► ENT

Alarm Information
1. 2018-10-31 31:63 R2-L
2. 2018-10-31 28:00 R2-N
3. 2018-10-31 31:63 C1-H
4. 2018-10-31 28:00 C1-L
ESC ▼ ▲ ► ENT

The figure above shows the display interface of system information and alarm information respectively.

System information: All setting parameters of the meter are displayed in the system information. Press Enter to enter the system information interface.

Alarm information: Up to 60 relay alarm messages can be stored. Press the ► button to enter the alarm information interface.

V Menu introduction

The instrument is divided into four first-level menus according to the function, and each level menu includes two or even two sub-menus. Each menu is numbered for easy viewing and setting of meter parameters.

Moreover, the secondary menu will display the setting parameters of the lower menu instrument according to the function at the upper right of the screen and the user can know the instrument parameters without entering the lower menu.

The main menu includes four first-level menus:

1. System setting The system setting parameters of the instrument include language, password, date, backlight, etc.
2. Sensor setting Includes display mode, calibration, digital filtering, temperature mode, temperature regulation, and compensation.
3. Output setting Including relay 1, relay 2, relay 3 and two 4-20mA settings.
4. Factory reset Including setting recovery and alarm information recovery.

Menu prompt function: Enter the secondary menu and the parameter settings for the next menu will be displayed at the top right of the screen.

For example, enter the backlight of the system setup menu, the backlight parameter is set to 30 seconds.

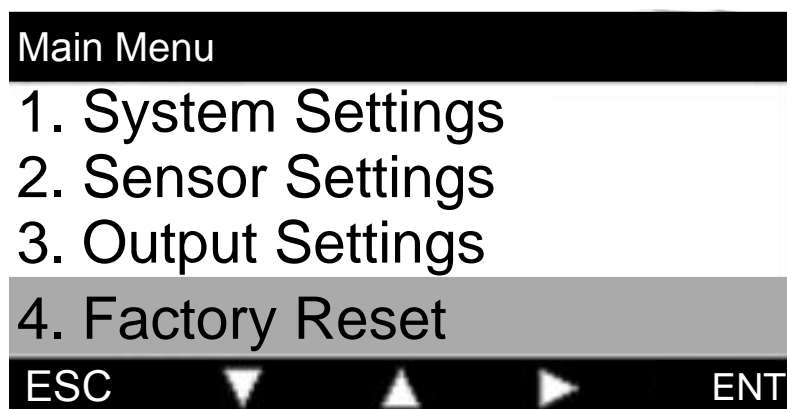

Menu 1.1 Language

Both options, English or Chinese, are confirmed by ENTER.

Language en

1.1.1 English

1.1.2 简体中文

ESC ▼ ▲ ▶ ENT

Menu 1.2 Password

The default password of this controller is "0000". You can change the password freely. After changing the password, the user will enter the new password after entering the setup menu next time.

Password Settings 0000

0000

ESC ▼ ▲ ▶ ENT

Menu 1.3.1 Date format

This controller supports the selection of three date formats, and you can select the appropriate date format according to your needs.

Date Format Y-M-D

1.3.1.1 Year-Month-Day

1.3.1.2 Day-Month-Year

1.3.1.3 Month-Day-Year

ESC ▼ ▲ ▶ ENT

Menu 1.3.2 Date settings

Enter the date setting menu to set the year, month, day, hour, minute, and so on.

After successful setting, the system time of the meter will automatically change to the set time.

Date Settings 2020

1.3.2.1 Year

1.3.2.2 Month

1.3.2.3 Day

1.3.2.4 Hour

ESC ▼ ▲ ▶ ENT

Menu 1.4 Backlight

This instrument supports four kinds of backlight time, the user can set the corresponding backlight time according to the demand. The screen will darken when the meter reaches backlight time.

Backlight	30s
1.4.1	30s
1.4.2	60s
1.4.3	120s
1.4.4	Always
ESC	ENT

5.2 Sensor Settings**Menu 2.1 Display mode**

This instrument supports 7 display modes, each display mode represents different measurement accuracy and measurement unit selection.

Display Modes	14.00 pH
2.1.1	14.00 pH
2.1.2	14.00 pH-Ti
2.1.3	±2000mV-ORP
2.1.4	14.0 pH
ESC	ENT

Remarks:

14.00PH : need to use pH sensor, the measuring range is 0.00-14.00PH.

14.00pH-Ti: need to use pH sensor(TI), the measuring range is 0.00-14.00pH.

±2000mV-ORP: need to use ORP sensor, the measuring range is -2000~+2000mv.

14.0pH: need to use PH sensor, the measure range is 0.0 – 14.0pH.

14.0pH-Ti: need to use pH sensor(TI), the measuring range is 0.0 –14.0pH.

14pH: need to use PH sensor , the measuring range is 0 – 14pH.

14pH-Ti: need to use pH sensor(TI), the measuring range is 0 – 14pH.

Menu 2.2 Coefficient settings This menu has two types:

2.2.1 Calibration 2-point

2.2.2 Calibration 3-point

Because the principle of two-point calibration is the same as that of three-point calibration, here we take two-point calibration as an example.

2.2.1 Cal. 2 Point

Two-point calibration includes low/high point calibration: the default setting of low-point calibration is 4.00pH. First, clean the probe and dry it. Insert pH probe into the buffer calibration solution of **pH 4.00**, observe the mV in the calibration page, wait for the mV to stabilize at **177.0mV(177±20)** and press **Enter** to save it. Then do high-point calibration **pH 7.00**, wait for the mV to stabilize at **0mV(0±20)**.

T-pH Sensor calibration process:
4.00pH buffer solution: -170±50mV
7.00pH buffer solution: -320±50mV

Low Cal. 4.00/177.0

4.00 pH

25.0 °C 177.0 mv

ESC ▼ ▲ ▶ ENT

High Cal. 7.00/0.0

7.00 pH

25.0 0.0 mv

ESC ▼ ▲ ▶ ENT

Menu 2.3 Digital filtering

The measured value of the meter is filtered by means of averaging, and three digital filtering methods are supported.

Low point: average every 5seconds

Midpoint: average every 10 seconds

High point: average every 20 seconds

Note: The rate of change of the low point is higher than the rate of change of the highpoint.

Digital Filter L

2.3.1 L

2.3.2 M

2.3.3 H

ESC ▼ ▲ ▶ ENT

Menu 2.4 Temperature mode

This controller support PT1000 and NTC10K temperature sensor.

Note 2.4.1 PTC°C: PT1000 temperature sensor, Celsius display mode.

2.4.2 NTC°C: NTC10K temperature sensor, Celsius display mode.

2.4.3 MTC°C: manual mode, Celsius display mode.

2.4.4 PTF°F: PT1000 temperature sensor, Fahrenheit display mode.

2.4.5 PTF°F: NTC10K temperature sensor, Fahrenheit display mode.

2.4.6 MTF°F: manual mode, Fahrenheit display mode.

Temp. Mode PTC

2.4.1 PTC°C

2.4.2 NTC °C

2.4.3 MTC °C

2.4.4 PTF °F

ESC ▼ ▲ ▶ ENT

Menu 2.5 Temperature Settings

The temperature adjustment is divided into two parts, the upper part is the temperature adjustment value, and the lower part is the adjusted temperature display value. Press **Enter**, the temperature display of the controller will be the adjusted value.

Temp. Settings 25.0

+25.0 °C

ESC ▼ ▲ ▶ ENT

Menu 2.6 Compensation

Users can set the temperature compensation parameters freely according to the actual situation.

After confirming by press **Enter** the measured values will change accordingly according to the temperature compensation parameters.

Note: The temperature compensation reference temperature of the instrument is fixed at 25 °C, and the calculation formula is:

$$C_t = C_{25}\{1 + \alpha(T - 25)\}$$

C₂₅ is PH/ORP value at 25 °C.
α is temperature compensation coefficient
T is temperature of the solution to be tested
C_t is temperature of T °C

Temp. Lin COMP 0.00%

00.00 %

ESC ▼ ▲ ▶ ENT

5.3 Output Settings

The output settings mainly include Relay 1, Relay 2, Relay 3 and 4-20mA settings, of which 4-20mA correspond to the measured values of temperature. The following takes the Relay 1 and 4-20 mA of pH as an example.

Menu 3.1 Relay 1 Settings

Relay 1 contains 3 sub-menus.

- 3.1.1 Relay-1 Mode
- 3.1.2 Relay-1 STOP
- 3.1.3 Relay-1 RUN

Relay-1 Settings Mode

- 3.1.1 Relay-1 Mode
- 3.1.2 Relay-1 STOP
- 3.1.3 Relay-1 RUN

ESC ▼ ▲ ▶ ENT

Menu 3.1.1 Relay-1 Mode

It has 8 modes: Off, High, Low, Within, outof, Time, High Temp, Low Temp.

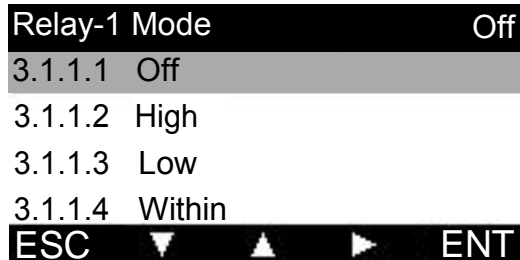

Menu 3.1.2 Relay-1 SP (trigger value)

The user can freely set the trigger value within the range allowed by the meter and press **Enter** to confirm.

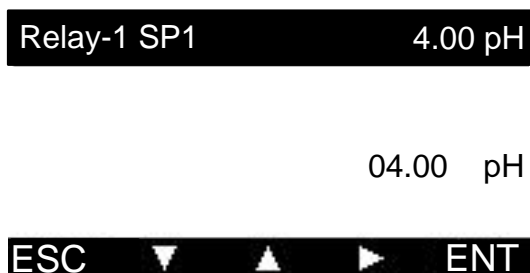

Menu 3.1.3 Relay 1 hysteresis value

The user can freely set the hysteresis value within the range allowed by the meter and press **Enter** to confirm.

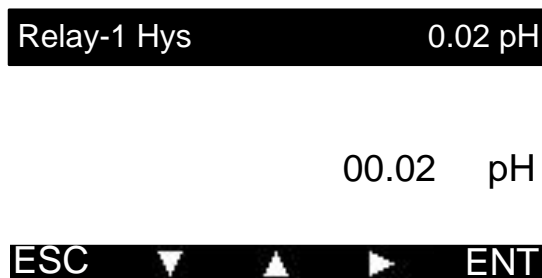

Relay-1 Mode Within

3.1.1.4 Within

3.1.1.5 Outof

3.1.1.6 Time

3.1.1.7 High Temp.



Menu 3.1.1.4 Within

The user can select the mode within the range of relay 1 according to the demand and press the **Enter** to determine.

Relay 1 trigger value 1=5.00
 Relay 1 trigger value 2=8.00
 Relay 1 hysteresis value = 1.00

This setting relay working state is: when the display value is lower than 8.00, the relay is suction; when the relay is below 4.00, the relay is disconnected, when the display value is higher than 5.00, the relay is suction; when the relay is higher than 9.00, the relay is disconnect.

Disconnect value = trigger value 1-hysteresis value = trigger value 2 + hysteresis value

Menu 3.1.1.5 Outof

The user can select the mode within the range of relay 1 according to the demand and press the **Enter** to determine.

Relay 1 trigger value 1=5.00
 Relay 1 trigger value 2=8.00
 Relay 1 Hysteresis value=1.00

When the display value is lower than 7.00, the relay is disconnect; lower than 5.00, the relay is suction; higher than 6.00, the relay is disconnect; higher than 8.00, the relay is suction.

Disconnect value=trigger value 1+ hysteresis=trigger value 2-hysteresis value

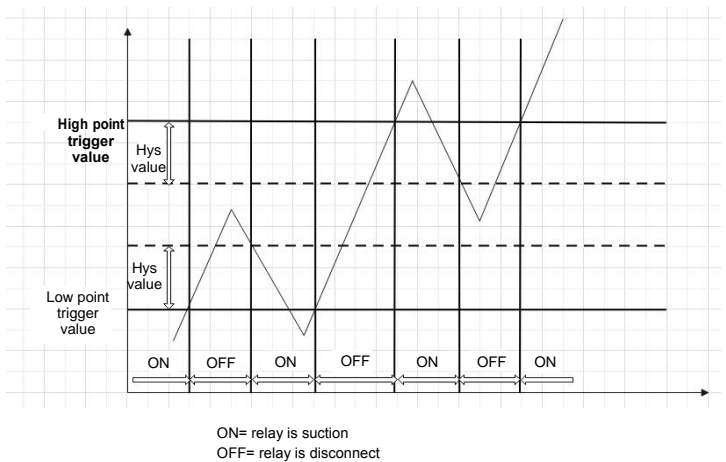

Menu 3.1.1.6 Time

STOP=5s, RUN=10s

The working status at this time is:Run continuously for 10 seconds, then rest for 5 seconds, then run for another 10 seconds, and rest for another 5 seconds.

This process is cyclical.

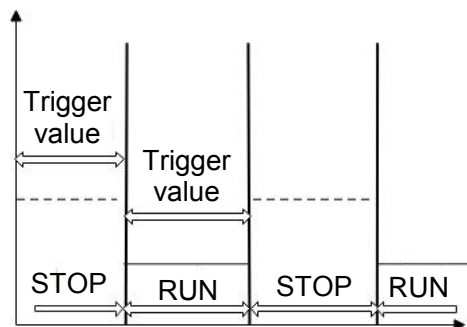

Menu 3.1.1.7 High Temp.

Relay 1 trigger value=30°C
 Relay 1 hysteresis value=10°C

When temperature is higher than 30°C, the relay is suction, lower than 20°C, the relay is disconnect.

Disconnect value=trigger value-hysteresis value

Note: 3.1.1.8 Low temp, Disconnect value= trigger value+hysteresis value

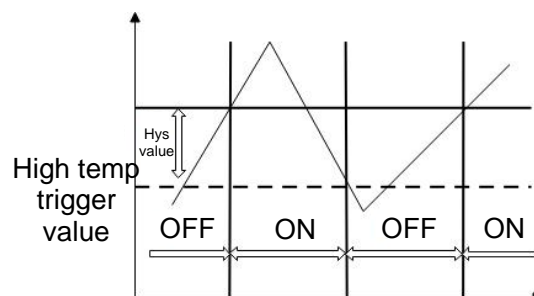

OFF= relay is disconnect, ON= relay is suction

Note:

Greater than (or less than) the alarm trigger value is pulled in. Below (or greater than) the hysteresis value is released.

The relay action diagram is as follows:

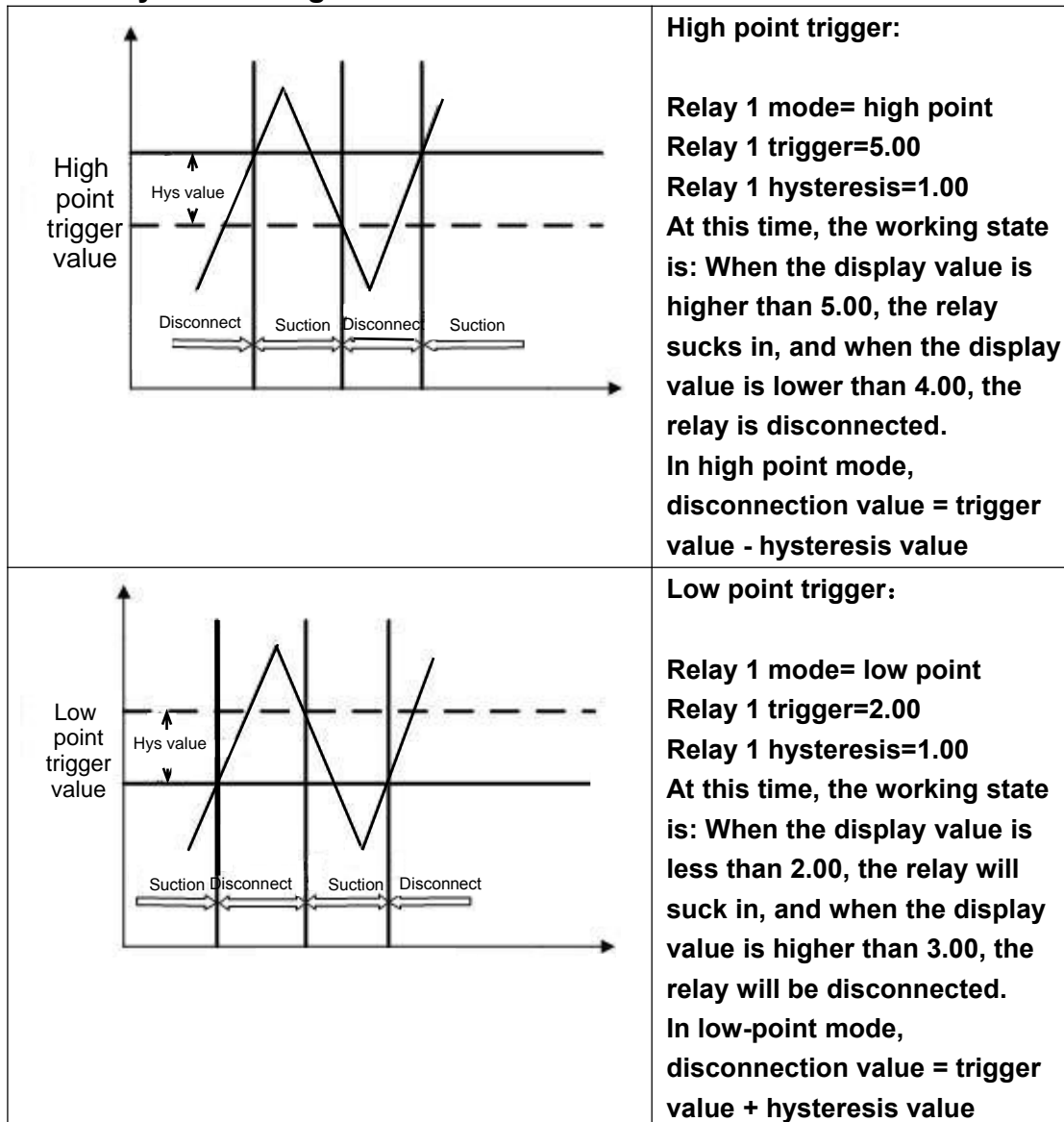

Menu 3.2 Relay 2

The settings of relay 2 is the same as the setting principle of relay 1, please refer to the setting of relay 1.

Menu 3.3 Relay 3

The settings of relay 3 is the same as the relay 1 and relay 2.

Menu 3.4 Current-1

Menu 3.5 Current-2

Output Settings

3.2 Relay-2

3.3 Relay-3

3.4 Current-1

3.5 Current-2

ESC ▼ ▲ ▶ ENT

Menu 3.4.2 Current-1 Set. 4mA

Current-1 Set.4mA 0.05 pH

00.05 pH

ESC ▼ ▲ ▶ ENT

Menu 3.4.3 Curren-1 Set. 20mA

Note: The dissolved oxygen value and current value set in 4-20mA correspond to each other, and the calculation formula is:

$$outMa = (20.00 - 4.00) / (endMa - startMa) * (hold - startMa) + 4.00$$

outMa is the value of output current

startMa: pH/ORP value set by 4mA

endMa: pH/ORP value set by

20mA Hold is present measured value

For example, 4mA is set to 0.00pH, 20mA is set to 14.00pH, and when the pH value is 7.00 PPM, the current output is 12.00mA.

Current-1 Set.20mA 0.05 pH

00.05 pH

ESC ▼ ▲ ▶ ENT

3.4.4 Current-1 Cal. 4mA

After entering the calibration interface, the current output value will be displayed on the screen. The ammeter will measure the output current value of the current 1 and adjust the current value on the screen to be the same as the current value measured by the ammeter.

Current-1 Cal.4mA 04.02mA

04.02 mA

ESC ▼ ▲ ▶ ENT

3.4.5 Current-1 Cal. 20mA

Current-1 Cal.20mA 19.86mA

19.86 mA

ESC ▼ ▲ ▶ ENT

5.4 Factory Reset

Menu 4. Factory Reset

Press Enter to confirm, all the parameter settings of the meter will be restored to the default value.

Menu 4.2 Alarm Reset

After pressing Enter key, the alarm information of the meter will be cleared.

Factory Reset

4.1 Settings Reset

4.2 Alarm Reset

ESC ENT

VI Default factory settings

Menu	Range setting	Factory default
Sensor type	PH/ORP/Ti	PH
Digital filtering	Low/middle/high point	Low point
Calibration	2-point/3-point	2-point
Temperature compensation	Auto/manual	manual
Manual temperature compensation	0.0 ~ 100.0 °C	25.0 °C
High point trigger value	pH: 0.00 ~ 14.00 pH	pH: 12.00 pH
	ORP : - 1999 ~ + 1999 mV	ORP : + 900 mV
High point hysteresis value	pH:0.00 ~ 14.00 pH	pH: 1.00 pH
	ORP : 0 ~ +1999 mV	ORP : 100 mV
Low point trigger value	pH: 0.00 ~ 14.00 pH	pH: 2.00 pH
	ORP : -1999 ~ +1999 mV	ORP : - 900 mV
Low point hysteresis value	pH: 0.00 ~ 14.00 pH	pH: 1.00 pH
	ORP : 0 ~ +1999 mV	ORP : 100 mV
4mA corresponding value	pH: 0.00 ~ 14.00 pH	pH: 0.00 pH
	ORP : - 1999 ~ + 1999 mV	ORP : - 1999 mV
20mA corresponding value	pH: 0.00 ~ 14.00 pH	pH: 14.00 pH
	ORP : - 1999 ~ + 1999 mV	ORP : + 1999 mV
User password	0 ~ 9999	0000 (general password:6666)

Maintenance

APURE controllers in general normal circumstances, do not need to do any maintenance, only electrodes need to be regularly cleaned and corrected to ensure accurate and stable measurements and maintain normal system movements.

The cleaning cycle of the electrode depends on the degree of contamination of the test water sample, in general, it is best to be able to clean and maintain regularly once a week: the following table for different properties of pollution, the required cleaning liquid to do an introduction explanation, to provide operators as a cleaning and maintenance reference:

General pollution	Clean the sensor with 0.1M NaOH or 0.1M HCL for serveral minutes.
Contamination of sensor diaphragm caused by protein in test solution	The sensor was immersed in Pepsin/HCL solution for several hours.
Sulfide contamination (black of sensor diaphragm)	The sensor was immersed in Thiourea/HCL solution until the diaphragm became white.
Pollution of grease or organic matter	The sensor was briefly cleaned with acetone or ethanol for several seconds.
Platinum sensor can be cleaned with clean cloth stained with water.	
When using the above method to clean the sensor, please rinse them thoroughly with clean water, and put the electrodes into 3M OL KCL solution for about 15 minutes, then do the sensor calibration again.	
During the sensor cleaning process, do not rub the sensor sensing glass head, or mechanical cleaning electrode, otherwise it will produce electrostatic interference, affecting the reaction.	

Note: The sensor cleaning cycle must depend on the degree of contamination of the water quality, it is generally recommended to clean and correct at least once a week, or according to the sensor operating instructions and the original recommended cleaning sensor(probe).

ModbusRTU Communication Protocol

Settings: 9600 N 8 1				
Protocol: MODBUS RTU				
FC CODE: 0x03 Reading 0x06 Modify				
FC	ADD	Name	Format	Expound
03	1008	Main data(pH, ORP, EC, DO, CL, etc)	IEEE754 32-bit	PH/ORP
03	1009			
03	1010	Temperature	IEEE754 32-bit	Temperature
03	1011			
03	1012	Main data Unit	INT16	Check list
03	1013	Temperature Unit	INT16	Check list
03/06	3600	Device address	INT16	Range: 1-255, (Unknow address modification by 00 AA 2C 01 FD 04. 01 is add,FD is 04CRC16 check)
03/06	3601	Baud rate	INT16	0:2400 1:4800 2:9600 3:19200
03/06	3100	Relay 1 output settings	INT16	0: no output 1: main data high point 2: main data low point 3: temperature high point 4: temperature low point
03/06	3101	Relay 1 trigger value	IEEE754 32-bit	
03/06	3102			
03/06	3103	Relay 1 hysteresis value	IEEE754 32-bit	
03/06	3104			

03/06	3200	Relay 2 output settings	INT16	0: no output 1: main data high point 2: main data low point 3: temperature high point 4: temperature low point
03/06	3201	Relay 2 trigger value	IEEE754 32-bit	
03/06	3202			
03/06	3203	Relay 2 hysteresis value	IEEE754 32-bit	
03/06	3204			
03/06	3300	Current 1 output settings	INT16	0: no output 1: measuring value 2: temperature
03/06	3301	Current 1-4ma corresponding value	IEEE754 32-bit	
	3302			
03/06	3303	Current 1-20ma corresponding value	IEEE754 32-bit	
	3304			

Example: Read the measurement
Device send command (Hexadecimal)

01	03	03	F0	00	02	C4	7C
Add	FC Code	Register Add	Register Add	Register Length high	Register Length low	CRC-high	CRC-low

Received:

01	03	04	00	00	40	E0	CA	7B
Add	FC Code	Data length	4 byte floats			CRC-high	CRC-low	

Note: Floating-point data is a 32-bit IEEE 754 format above the table as an example, divided into two 16-bit register data transmission, the last 16-bit register (00 00) first pass, the first 16-bit register (40 E0) data pass, each 16-bit format is high before, low after. For example, now that ph measures bit 7.00, the 16-step of floating points is displayed as 40 E0 00 00 and the transfer order is 00 00 40 E0

Unusual response format description:

If the sensor does not perform the upper computer command correctly, the following format information is returned:

	Add	FC Code	CODE	CRC-check
Data	ADDR	COM+80 H	xx	CRC 16
Byte	1	1	1	2

a) CODE:

01 - Illegal function code

02 - Illegal data address bit

03 - Illegal data

b)COM: The received function code

List

0	无单位	1	PH
2	MV 毫伏	3	V 伏
4	$\mu\text{s/cm}$	5	ms/cm
6	Ω 欧姆	7	K Ω 千欧
8	M Ω /cm 兆欧	9	mg/L
10	ppm	11	% 百分比
12	‰ 千分比	13	nA 纳安
14	mA 毫安	15	NTU
16	FTU	17	EBC
18	JTU	19	mm/a 毫米/年
20	Mpy 密耳/年	21	mil/a 密耳/年
22	$\mu\text{A/cm}^2$ 微安/厘米 ²	23	mg/(dm·d) 毫克/ (分米·日)
24	Mdd 毫克/ (分米· 日)	25	g/(m·h) 克/ (米· 时)
26	g/(m·d) 克/ (米· 日)	27	°C 摄氏度
28	°F 华氏度	29	°K 开尔文温度
30	Year 年	31	Month 月
32	Day 日	33	Hour 时
34	Mintues 分	35	Second 秒
36	Bar	37	ph-TI